

**HMD-FOC Hot Metal Detector
Static Mode Fiber Optical Cable
Operator's Manual**

Revision 1.02



Contents

| | |
|--|----------|
| 1. INTRODUCTION | 2 |
| 2. DESCRIPTION | 2 |
| 2.1 Model Nomenclature | 2 |
| 2.2 Specifications | 3 |
| 2.3 Operating Principle | 3 |
| 2.4 Sensitivity Adjustment | 3 |
| 3. OPTICAL LENS AND CABLE | 4 |
| 3.1 A1 Lens..... | 4 |
| 3.2 B1 Lens..... | 5 |
| 3.3 Fiber Optical Cable | 5 |
| 3.4 HMD Enclosure | 6 |
| 4. WIRING CONNECTIONS | 6 |
| 4.1 Electrical Connections | 6 |
| 4.2 Purge Air Connection | 7 |
| 5. OPERATION | 8 |
| 5.1 Controls | 8 |
| 5.2 Automatic Threshold Level Description..... | 8 |
| 5.3 Self Test | 8 |
| 5.4 Troubleshooting..... | 9 |
| 6. MAINTENANCE | 9 |
| 6.1 Regular Maintenance | 9 |
| 6.2 Returns of HMD-ST-FOC | 10 |

1. Introduction

The Logika Technologies static mode hot metal detector, Model HMD-ST-FOC, is designed to detect hot metals (above 360°C) and aid in the automation of steel, aluminum and other industrial applications. It includes a rugged IP66 enclosure protecting state-of-the-art electronics and will withstand the harsh ambient conditions present in heavy industrial environments. The HMD-ST-FOC is used primarily for detection of hot metals in applications such as wire rod, bar, strip, thin plate, thick plate, billet and slab in production.

2. Description

2.1 Model Nomenclature

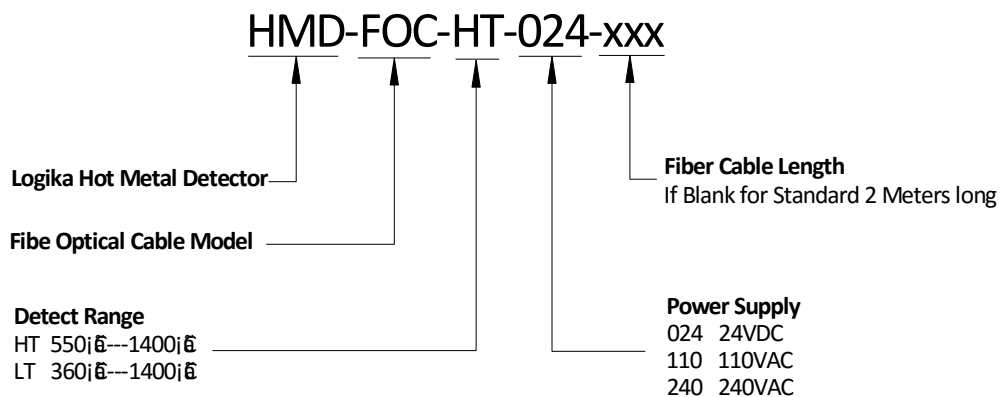

2.2 Specifications

| | |
|--|---|
| Electronics part Operating temp | -25°C to +70°C (-13°F to +158°F). |
| Detect Range | 0.2-8m |
| Response time | Relay < 20 ms, PNP/NPN < 2 ms |
| LED Indicators | Green = power on, Red = target detect |
| Output | Relay 30VDC/220VAC @ 5A High on Detect(PNP): max 100mA Low on Detect (NPN): max 100mA |
| Power Input | 24 VDC, 110VAC, 220VAC @ 5W |
| Fiber Cable | Standard 2 meters long, other length is available on request |
| Cable for electronics part | 2.5 meters, 11 conductors, steel braided |
| Sensor detect Infrared range | HT Model: 500°C-1400°C, 700nm-1200nm LT model: 360°C-1400°C, 900nm-1700nm, |
| Self testing | TEST PIN |
| Protection | DC polarity, output overload, short circuit protection |
| Weight | 1.3 kg (2.8 Lbs) |

2.3 Operating Principle

Detector - The HMD-ST-FOC receives infrared radiation from high temperature objects and transmits the light energy through a specially designed fiber optical cable onto a photo sensor inside the HMD. This light energy is then converted into an electrical signal.

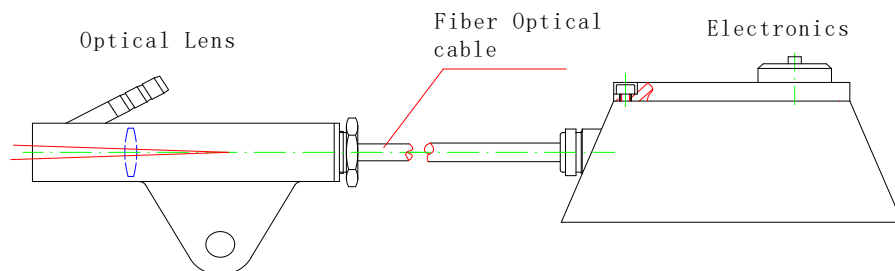

Figure 1: HMD-ST-FOC Overview

2.4 Sensitivity Adjustment

This feature makes the HMD more stable and reduces detection errors caused by background infrared radiation sources, varying surface temperature or interference from water vapor and scale.

Web: www.logikatech.com **Phone:** 905-597-7272 **Fax:** 905-597-7278 **Email:** info@logikatech.com

3. Optical Lens and cable

3.1 A1 Lens

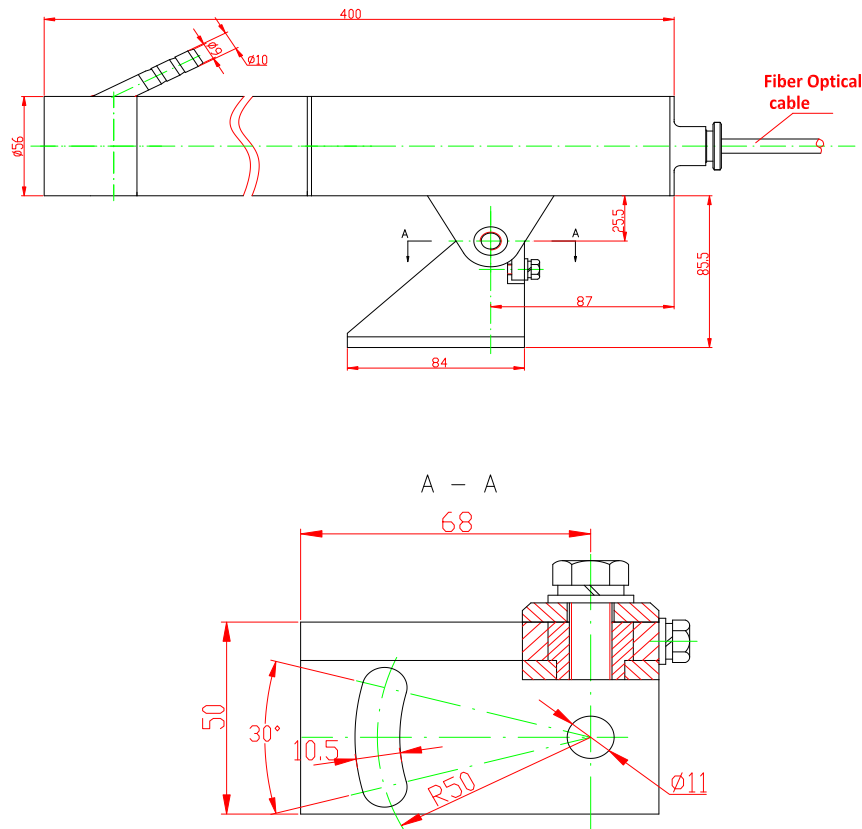

| | |
|---|--|
| Lens housing | Cylindrical, Stainless Steel, with air purge |
| Ambient Temperature | -25 °C ~ 300 °C (-13 °F ~ 572°F) |
| Field of View (Target temperature at 700 °C) | No Ring: 1.8° 8mm Ring: 1.5°(Default) 6mm Ring: 0.85° 4mm Ring: 0.6° 2mm Ring: 0.55° |
| Installation angle | ±45° |
| Air Purge | Pressure 0.1MPa (14 psi), Volume 6L/min (0.21 cfm) |

3.2 B1 Lens

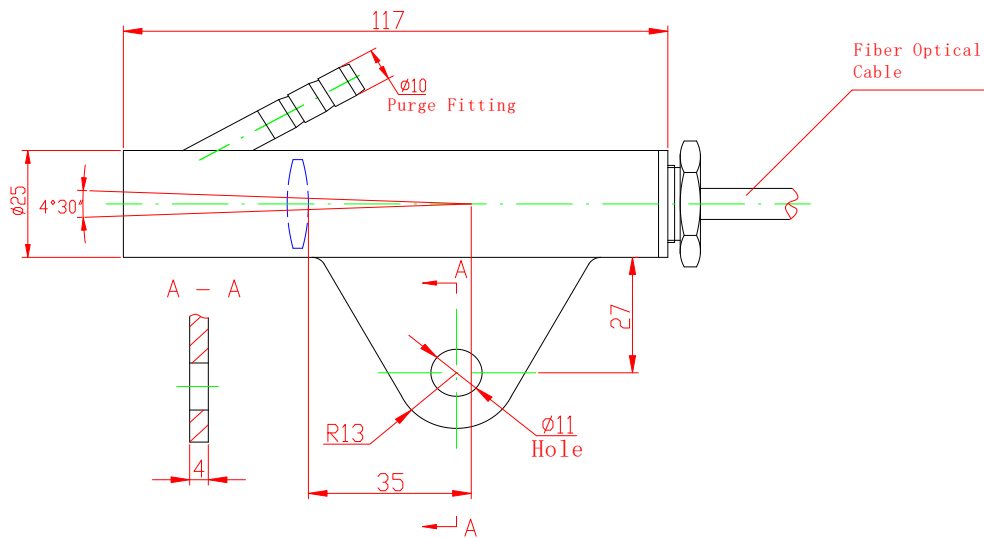

| | |
|---------------------|--|
| Lens housing | Cylindrical, Stainless Steel, with air purge |
| Ambient temperature | -25 °C ~ 300 °C (-13 °F ~ 572°F) |
| Field of View | 4.5° (other views can be special ordered) |
| Installation angle | ±45° |
| Air Purge | Pressure 0.1MPa (14 psi), Volume 6L/min (0.21 cfm) |

3.3 Fiber Optical Cable

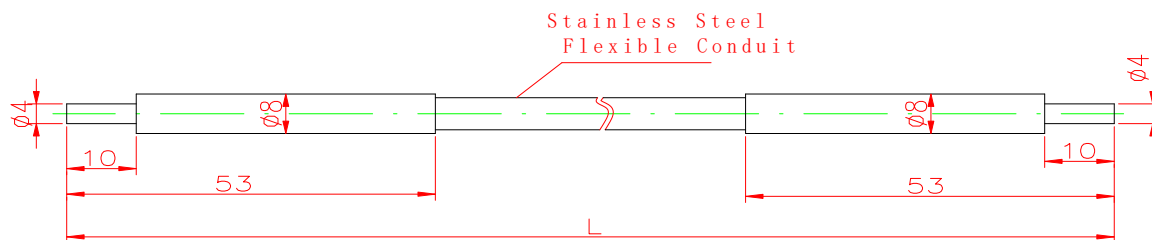

L: 2m standard, other lengths are available on request

3.4 HMD Enclosure

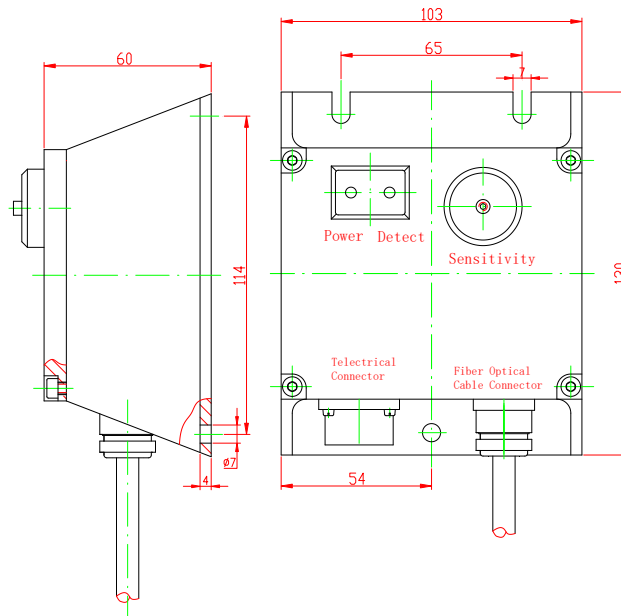

4. Wiring Connections

4.1 Electrical Connections

Electrical Overview- All electrical connections (power and signal) to the HMD-ST-FOC are made via a 12-pin connector with ground. The HMD is supplied with a mating connector at the back of its enclosure and a standard 2-meter cable with a quick-connect assembly. This cable is also wired with ferrule terminals for the junction box connections. Custom cable lengths are available from Logika Technologies upon request.

Cable Specifications

- Multi-lead cables – 11 x 0.34 mm²
- Outer metallic braid for mechanical protection.
- Overall diameter of 9 mm.
- Minimum bending radius of 30 mm.

Note: Static and Relay output are isolated, allowing the two types of outputs to be used separately or at the same time.

Web: www.logikatech.com **Phone:** 905-597-7272 **Fax:** 905-597-7278 **Email:** info@logikatech.com

| Number | Color | Pin No. | Function |
|--------|--------|---------|--------------|
| 1 | Brown | K | +24VDC /AC L |
| 2 | Red | M | 0V DC/AC N |
| 3 | Orange | A | +24VDC Out |
| 4 | Yellow | B | 0VDC Out |
| 5 | Green | G | Earth |
| 6 | Blue | J | PNP (S) |
| 7 | Purple | L | Self test |
| 8 | Gray | D | Relay NO. |
| 9 | White | E | Relay COM |
| 10 | Pink | F | Relay NC. |
| 11 | Black | C | NPN (/S) |

Figure 4.1 Cable Terminal Wiring Table

4.2 Purge Air Connection

- **Description-** Compressed plant air should be used to protect the lens from dust and vapor. Purge air cleans the lens, reduces maintenance time, and prolongs HMD-ST-FOC's life in dusty or corrosive environments.
- **Compressed Air Requirements**
 - Must be clean, dry instrument air. Poor air quality will result in a dirty lens and decrease detector performance. Air filtration prior to the inlet fitting is recommended to improve the quality of purge air.
 - Air Pressure range from 4.9 to 19.6 kPa (0.7 psi to 2.8 psi)
 - Air Flow rate from 4 to 16 L/min (0.14 to 0.56 ft³/min)
- **Connection-** Connect plant air to the purge air barbed fitting on the detector's lens shroud with Φ 10mm ID (or 3/8" ID) hose. Purge air flows out of the lens and dissipates into the environment.

5. Operation

5.1 Controls

The HMD-ST-FOC's control panel is located on the top of the housing. The following functions are available on the control panel.

LED1 = **Green**: Power is on.

LED2= **Red**: Hot target is detected

Potentiometer = Sensitivity range adjustment

5.2 Automatic Threshold Level Description

- **Definition**- The HMD-ST-FOC includes an Automatic Threshold Level Adjustment. The HMD's circuitry will automatically decrease the threshold level when hot metal enters the target area to prevent signal saturation. When the hot target leaves the detection area the threshold level returns to its initial setting.

- **Sensitivity**- Adjust the Threshold Level Potentiometer upon installation to determine the base detector signal according to the application requirements. As the potentiometer setting increases from low to high (rotating clockwise), the HMD sensitivity (gain) increases. This enables the user to prevent interfering background radiation from resulting in false positives of the HMD's output. The lower the potentiometer setting, the hotter the target should be and greater interfering background radiation will be eliminated.

5.3 Self Test

To test whether the HMD is in working condition, follow steps below:

- Connect power to the HMD to make sure green LED is on.
- Use multi-meter to measure the voltages on PNP output pin (Blue) and NPN output pin (Black), referring to 0VDC pin (Yellow):

1. For PNP output: 0VDC
2. For NPN output: 24VDC

Measure the connection of Relay:

NO (Normally Open) pin (Gray) – Common (White) disconnected

Web: www.logikatech.com **Phone:** 905-597-7272 **Fax:** 905-597-7278 **Email:** info@logikatech.com

NC (Normally Closed) pin (Pink) – Common (White) connected

- Connect Self test Pin (Purple) to 0VDC Pin (Yellow), Red LED will be ON. Use multi-meter to measure the voltages on PNP output Pin (Blue) and NPN output pin (Black), referring to 0VDC pin (Yellow):

1. For PNP output: 24VDC
2. For NPN output: 0VDC

Measure the connection of Relay:

NO (Normally Open) pin (Gray) – (White) connected

NC (Normally Closed) pin (Pink) – Common (White) disconnected

5.4 Troubleshooting

- **Missed Target-** If the LED does not turn red when hot metal is in its detection field:
 1. The threshold potentiometer is set too low. Go to Threshold Sensitivity Adjustment, Section 5.2, and recalibrate the sensitivity adjustment.
 2. Check HMD's location and make sure the detection field covers hot metal.
- **Detector sends false target detect output**
 1. The sensitivity is set too high. Refer to Section 5.2, adjust sensitivity.
 2. If step 1 does not correct detector sending false output, check for background sources of radiation such as reflected sunlight or hot objects close to the detector. Adjust the Lens direction to make sure the disturbance as little as possible, or blocking the interfering radiation source.
- **Additional notes**
 1. No Power- Check that the wiring connections are correct, that the connections are secure and tight and that the power supply is proper and normal.

6. Maintenance

6.1 Regular Maintenance

- **Diagnostics-** the HMD-ST-FOC does not require maintenance at a fixed period other than periodic attention to the following to ensure consistent operation:
 - **Lens Cleaning-** Routinely check the lens glass for dust or oil residue. Clean as required with soft lint free cloth and lens cleaner.
 - **Adjustments-** The level of sensitivity (see Section 5.2)

Web: www.logikatech.com **Phone:** 905-597-7272 **Fax:** 905-597-7278 **Email:** info@logikatech.com

6.2 Returns of HMD-ST-FOC

- Contact Logika Technologies at (1-888-856-4452 (1-888-8LOGIKA) with the Serial Number of your HMD before you return our product. If we are unable to solve the problem by phone or email, Logika will provide you with a return authorization number.
- Do not return the HMD-ST-FOC without an authorization number.
- If the product is out of warranty, we will provide a repair estimate and then complete the repairs after your approval.